

LINAX

www.linax.co.jp 株式会社 **ライナックス**



Floor Grinder

Make proper use of different
original cutters for different
floorings and conditions

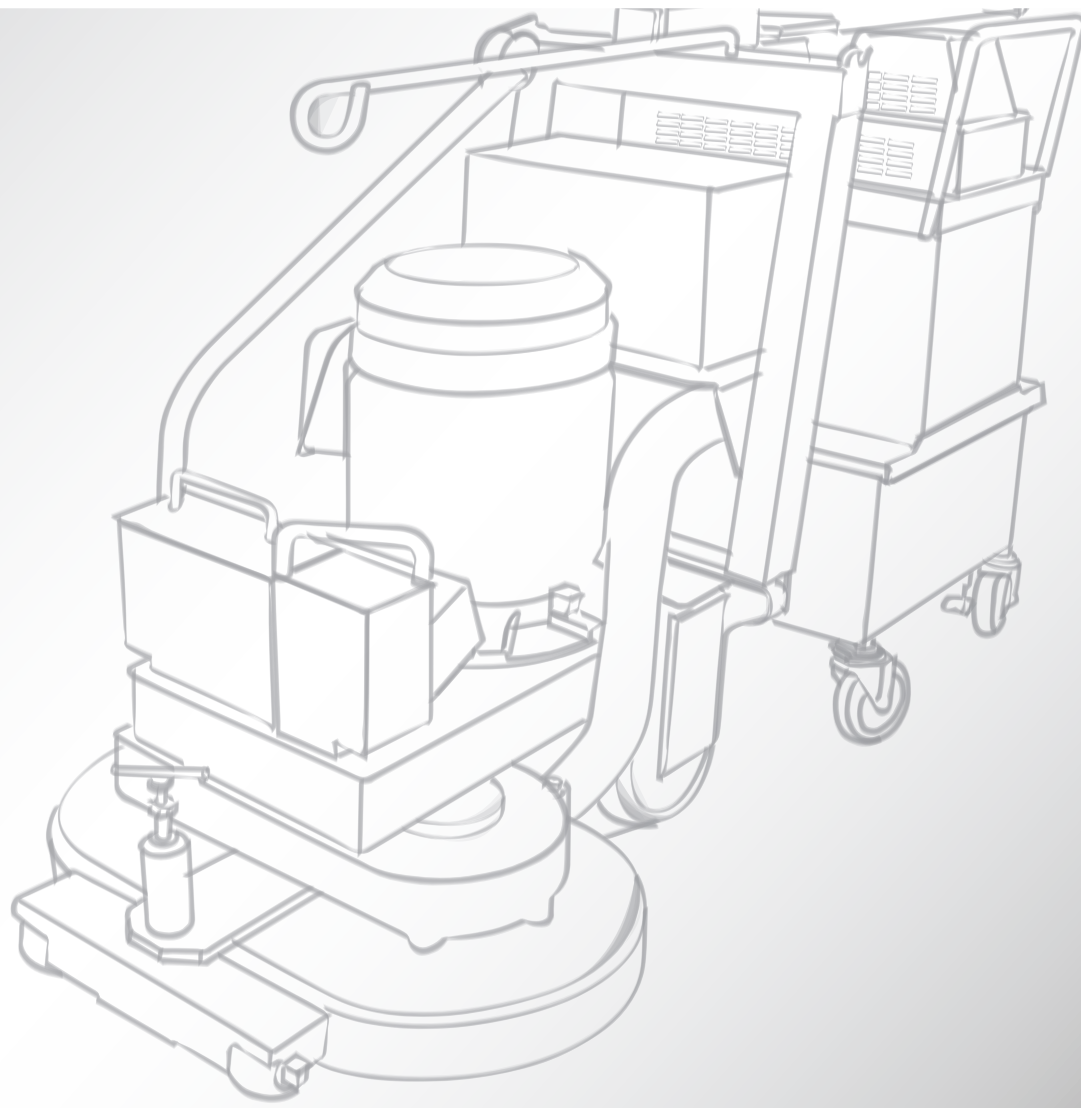

Floor Grinder series

- Realize an ideal floor finishing.
- Prepared with different kind of cutters for various floor application.
- Equipped with dust collection system.



Floor Grinder

HX-100 Hyex Sander

Power (V)	110 / 220 / 240
L x W x H (mm)	300 x 160 x 169
Total Weight (kg)	2.7
RPM (rpm)	12,000
Voltage (V)	110 / 220 / 240
Hertz (Hz)	50 / 60

Power (V)
L x W x H (mm)
Total Weight (kg)
Grinding Width (mm)
Motor (kW x Pole)
Technical Data of Dust Collector
L x W x H (mm)
Total Weight (kg)
Power
Max. Wind Power (m ³ /min)
Dust Tank Capacity (L)



K-20E Porche	K-30EN Electric Type	K-30N Gasoline Type
Single phase 220 x 5A	Triple phase 380 ~ 440 x 8.0A	Unleaded Gasoline
1036 x 408 x 894	1200 x 400 x 896	1280 x 415 x 897
42	103	98
200	300	300
1.0 x 4 (5 HP)	3.7 x 4 (5 HP)	Max 6.5HP
L-1 Model		
360 x 360 x 790	-	-
22	-	-
Single-Phase 220V x 5A	Single-Phase 220V x 5A	Single-Phase 220V x 5A
2.8	3.0	3.0
18	15	15

HX-100

Hyex Sander

Standard Accessories

- Grinding Cup "FLAT 100"
- High-exhaust Filter 3pcs
- Extra Skirt
- Single-ended Wrench
- Lock Nut Wrench
- Suction Hose (32mm x 2m)

High power dust exhaust system.



Attached with Dust Collection filter bag for dustless operation.



Features

- High power dust exhaust system allows dust directly to filter bag without vacuum.
- Create 99.99% dust control operation.
- Attached with brush skirt for easy suctioning dust on uneven floor.
- Suitable to use in tight areas where vacuum machine is unavailable.



Selection of Cutters for HX-100:



NEO ULTRA 100

Cutting application. Removal of thin materials up to 1mm. such as hard/soft resin coatings, exterior wall paintings, adhesives, etc.



FLAT 100

Smooth grinding on concrete, stone, hard resin coatings, etc. Create smoother surface.



SINGLE 100

Grinding concrete, stone, hard resin coatings, etc. High speed grinding on uneven surface, performs efficient working output.



FINE 100

For smooth and fine surface finishing. Special segments designed for anti-clogging and well grinding performance.

Features

- Compact and light weight.
- Suitable for light grinding and removal of thin coatings.
- Designed with dust collecting system.

पोर्चे
Porche



100% CLEAR UP WALL-EDGE REMAINDER

By just take off the side cover and adjust the rear wheel in 15°, enable to grind along the wall-edge.



Complete with:



BLOCK TIP (4pcs set)

Cutting thin materials up to 2mm. Removal of thin coatings, epoxy, acrylic, urethane, oil sludge, adhesives, etc.



BLOCK DIA BLACK (3pcs set)

Grinding concrete floor. Removal of laitance, trowel marks, raindrop marks, etc.



Perform deeper grinding for rougher surface.



Perform lighter grinding for smoother surface.

Porche

ATTACHED WITH DUST COLLECTOR

Designed with dust collecting system. V-1 dust collector is directly attached behind the grinder for dustless operation.



SUPER LIGHTWEIGHT ONLY 42KG !!

Portable and easy carry up and down stairs at jobsites. No need to use any power gate or crane.



REVERSIBLE PLATE

High performance plate. Block Tip and Block Dia can be installed on the same plate. Save time, and easy cutter changing.



K-30EN/N

Single Disc Grinder

Standard Accessories

Grinding Cutter "FLEXI RED"

Allen Wrenches (3, 5 & 6 mm)

Open-ended Spanner (10 x 12)mm

Open-ended Spanner (17 x 19)mm

Pliers

Sandbags 5pcs

Transformer Fuse (for electric type)

Plug Wrench (for gasoline type)

Selection of Cutters for K-30EN/N:

Choose the cutters wisely according to job application, desired finishing of concrete surface, floor materials, etc.

FLEXI SERIES

Create lighter scratches, smooth grinding.



FLEXI RED

Medium bond for grinding normal concrete.



FLEXI YELLOW

Soft bond for grinding hard concrete.



FLEXI BLUE

Hard bond for grinding soft concrete.



FLEXI GREEN

Fine grinding.
Surface preparation for thin coatings.

Features

- High performance concrete cutting
- Equipped with a dust collection system to create an environmentally friendly jobsite
- Completely dry concrete cutting system with very fast operations
- Millimetric adjustable cutting depth

K-30EN

Electric and Gasoline Models Available

LOCKUP SERIES

Create deeper scratches, rough grinding.



LOCKUP RED

Medium bond for grinding normal concrete.



LOCKUP PURPLE

PCD cutter.
Highly effective for removal of various coatings up to 2mm.



LOCKUP YELLOW

Soft bond for grinding hard concrete.



K-30N





Floor Grinder



株式会社 **ライナックス**

本 社 〒359-0027
埼玉県所沢市松郷151-6

☎ 04-2946 5211 🌐 www.linax.co.jp
☎ 04-2946 5212 ✉ linax@linax.net

LINAX CO., LTD.

Head Office: 151-6 Matsugo, Tokorozawa-shi,
Saitama-ken, 359-0027 Japan

☎ 81-4-2946 5211 🌐 www.linax.co.jp
☎ 81-4-2946 5212 ✉ linax@linax.net

